



**ECO  
LIGHT**  
*INDUSTRIAL LED*

**LED  
INDUSTRIAL  
FLOOD  
LIGHT**

**LEDIFL19-15AC**

## ROBUST INDUSTRIAL LED FLOOD LIGHTS – 15W

This fitting has been designed as a small, compact true industrial grade LED solution. It has a very robust construction, anti-glare frosted lens and light output that makes it suitable to replace up to 250W self-ballasted mercury fittings.

This light is commonly used for exterior lighting at industrial sites replacing energy hungry self ballasted mercury lamps. The styling of the light makes it equally useful as exterior lighting at home to replace troublesome twin halogen spotlight fittings.



### TECHNICAL SPECIFICATIONS

Fixture/Part No.	LEDIFL19-15AC
Total Power	15W
LED Power	13W
LED Lumens	1275lm
Fixture Lumens	1200lm
LED Lighting Efficiency	>90%
Colour Temperature	Cool White (CW) - 5700K Warm White (WW) - 3000K
Colour Rendering (Ra)	>70
IP Rating	IP65
Life Span	50,000 hours
Eco-friendly	No UV, IR, Lead or Mercury
Operating Temperature	-40°C to 50°C
Weight	0.71kg
Beam Angle	76.5°
Size	Diameter 150mm, Height 100mm
Dimmable	No
Power Factor	>0.8
Input Voltage Range	86-230V AC
Power Cable	3 core, 1.5m length
Powder Coating	Anti-corrosion Black
Housing Construction	Die Cast Aluminium, Tempered Glass
Aluminium Properties	LM6 - Si: 13%, Cu: 0.6%, Mn: 0.6%, Fe: 1.2%, Zn: 1.3%, Al: 83.3%
Lens	Toughened Glass - shatters on heavy impact (acrylic lens available on special request)
Bracket	Adjustable Aluminium with Black Powder Coating



**ECO  
LIGHT**  
[www.ecolight.co.nz](http://www.ecolight.co.nz)

**PRODUCT IMAGES**



**DIMENSIONS**

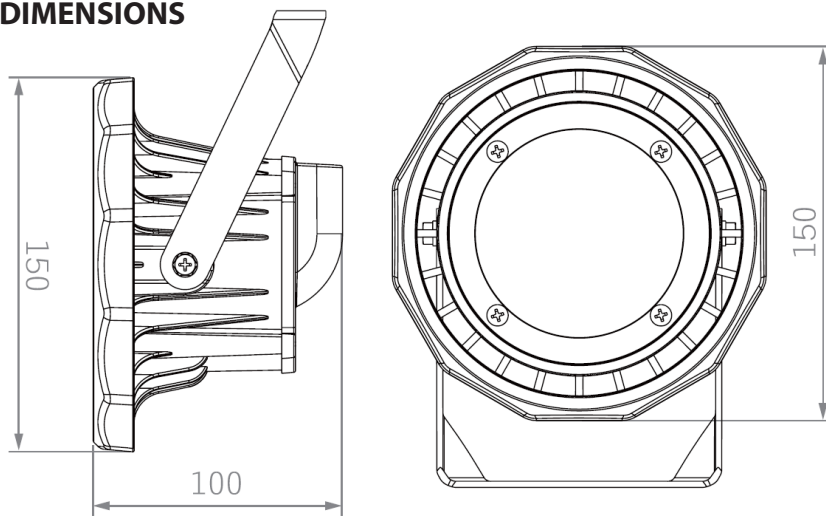

**PHOTOMETRICS**

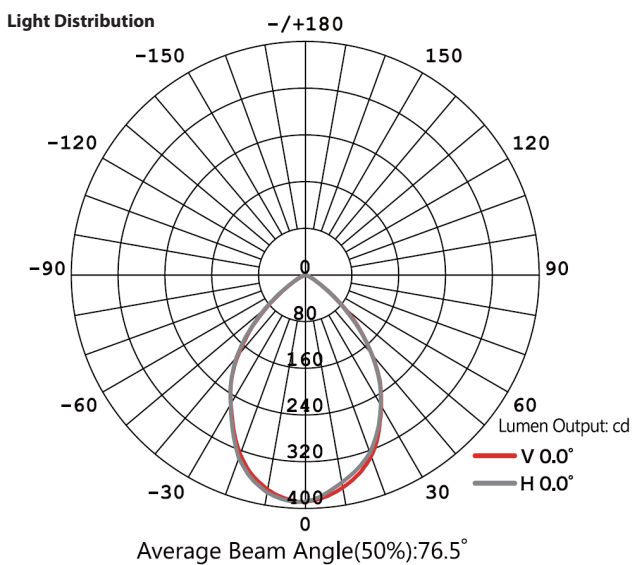

**ISO Candela Diagram**

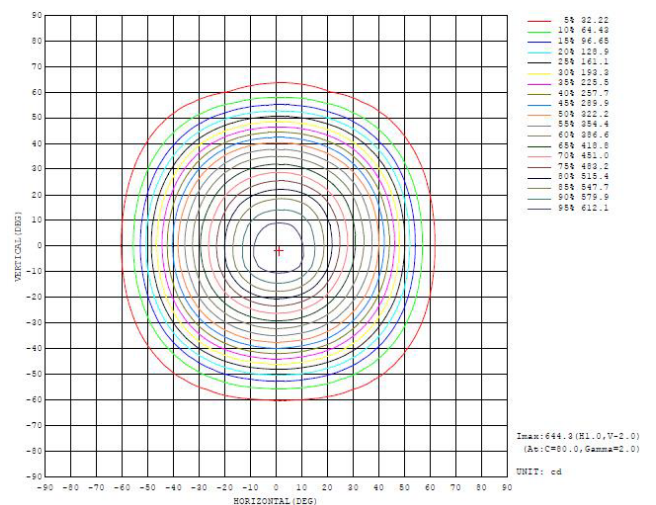

20 Neilpark Drive  
 East Tamaki  
 Auckland.  
 NEW ZEALAND  
 phone: 64 9 272 5619